

CONSEW®

PARTS LIST パーツリスト

146RB - * A-1

199RB - * A-1

199R - * A-1

146RBL - * A-1

199RBL - * A-1

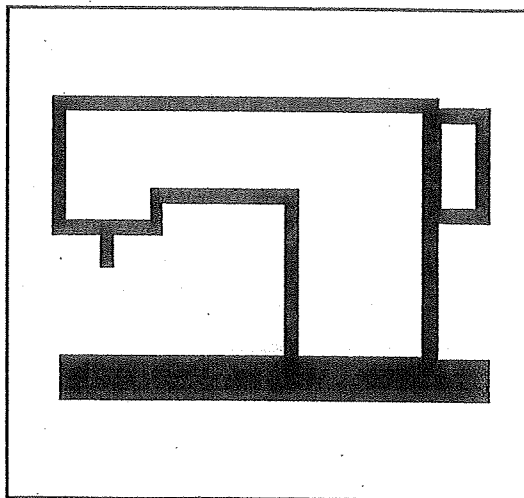



CONSOLIDATED SEWING MACHINE CORP.
U.S.A · JAPAN

INDEX

	pages
* 本体部分 BODY & IT'S ACCESSORIES	1-2
* 縫機構 SEWING MECHANISM	3-6
* 押え機構 PRESSER FOOT MECHANISM	7-8
* 上部送り機構 UPPER FEED MECHANISM	9-10
* 縫目調節、下送り機構 STITCH LENGTH REGULATOR & LOWER FEED MECHANISM	11-16
* 針棒揺動機構 NEEDLE ROCK MECHANISM	17-18
* 付属品 ACCESSORIES	19-20

OPTION PARTS

機種 Model	カム Cam	針振動ギア Needle vibrating worm wheel	針振受ギア Needle vibrating worm gear	縫い形式 Form
1A	606a	601a	603a	
2A	606	601	603	
3A	606b	601a	603a	

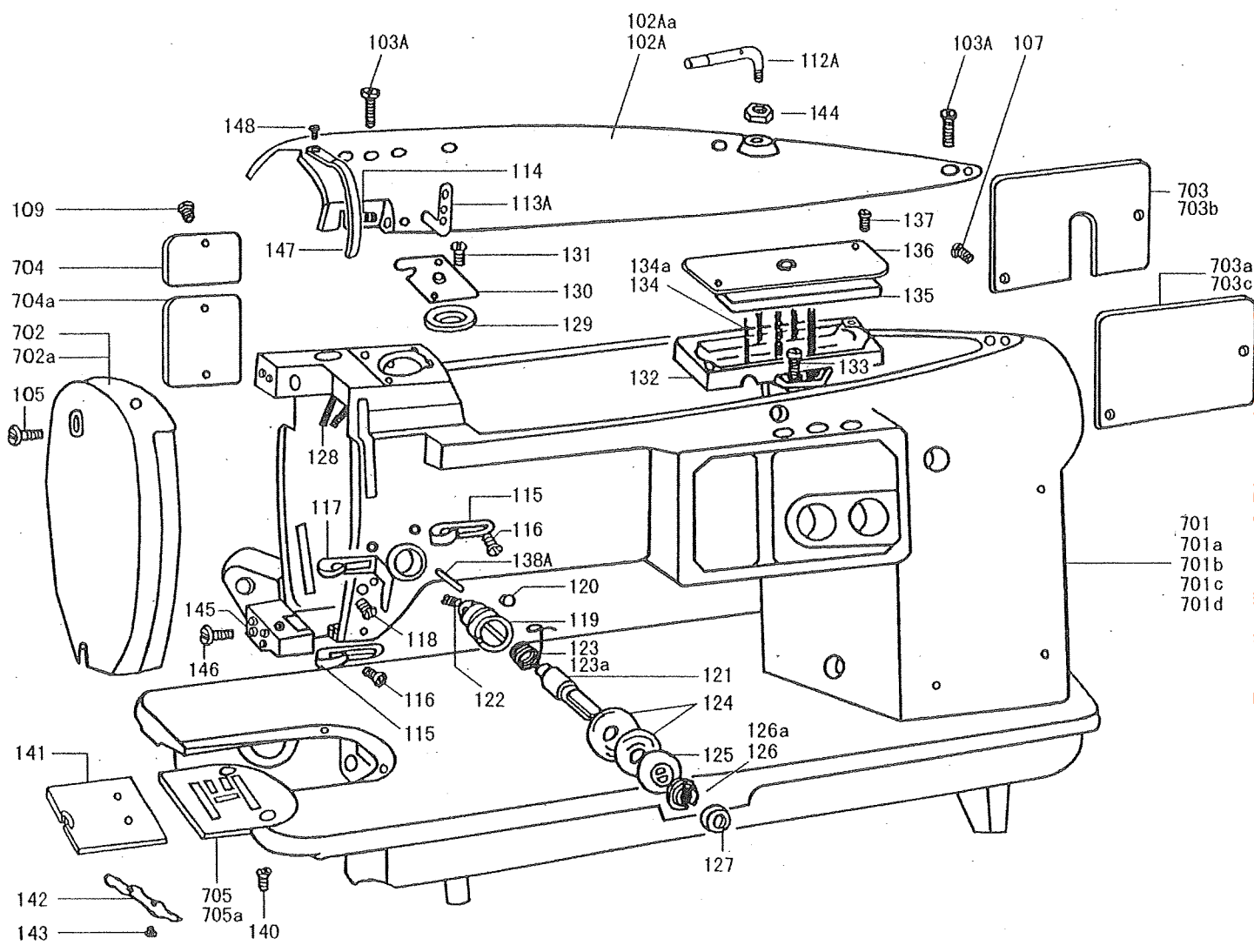

From the library of: Diamond Needle Corp

本体部分

BODY & IT'S ACCESSORIES

NO	部品番号 PART NO	146RB-	199RB-	199R-	146RBL-	199RBL-	品名	PARTS NAME
		*A-1	*A-1	*A-1	*A-1	*A-1		
1	102A	1	1	1			アーム上面カバー	Top cover
2	102Aa				1	1	アーム上面カバー	Top cover
3	103A	2	2	2	2	2	アーム上面カバー締ネジ	Screw 3/16"(4.76)×32/18
4	105	2	2	2	2	2	面板締ネジ	Screw 9/64"(3.57)×40/10
5	107	2	2	2	2	2	側板(大)締ネジ	Screw 9/64"(3.57)×40/6.5
6	109	1	2	2	1	2	側板(小)締ネジ	Screw 9/64"(3.57)×40/6.5
7	112A	1	1	1	1	1	上板糸掛	Thread guide
8	113A	1	1	1	1	1	三ツ目糸掛	Three hole thread eyelet
9	114	1	1	1	1	1	三ツ目糸掛締ネジ	Screw 11/64"(4.37)×40/5.5
10	115	2	2	2	2	2	アーム糸掛(上下)締ネジ	Arm thread guide
11	116	2	2	2	2	2	アーム糸掛(上下)締ネジ	Screw 9/64"(3.57)×40/6
12	117	1	1	1	1	1	大糸掛	Tension post thread guide
13	118	1	1	1	1	1	大糸掛締ネジ	Screw 9/64"(3.57)×40/6
14	119	1	1	1	1	1	糸調子棒台	Tension post rocket
15	120	1	1	1	1	1	糸調子棒台締ネジ	Screw 15/64"(5.95)×28/10
16	121	1	1	1	1	1	糸調子棒	Tension post
17	122	1	1	1	1	1	糸調子棒止ネジ	Screw 9/64"(3.57)×40/4
18	123	1	1		1	1	糸取りバネ	Take up spring
19	123a			1			糸取りバネ	Take up spring
20	124	2	2	2	2	2	糸調子皿	Tension disk
21	125	1	1	1	1	1	糸調子皿押エ	Tension release washer
22	126	1	1		1	1	糸調子バネ	Tension spring
23	126a			1			糸調子バネ	Tension spring
24	127	1	1	1	1	1	糸調子ナット	Tension nut
25	128	1	1	1	1	1	油タンク(前)組紐	Oil wick
26	129	1	1	1	1	1	油タンク(前)フェルト	Felt
27	130	1	1	1	1	1	油タンク(前)カバー	Oil tank (Front) cover
28	131	2	2	2	2	2	油タンク(前)締ネジ	Screw 9/64"(3.57)×40/6.5
29	132	1	1	1	1	1	油タンク(後)	Oil tank (Rear)
30	133	2	2	2	2	2	油タンク(後)締ネジ	Screw 9/64"(3.57)×40/11
31	134	7	7	7			油タンク(後)組紐	Oil wick
32	134a				5	5	油タンク(後)組紐	Oil wick
33	135	1	1	1	1	1	油タンク(後)フェルト	Felt
34	136	1	1	1	1	1	油タンク(後)カバー	Oil tank (Rear) cover
35	137	2	2	2	2	2	油タンク(後)カバー締ネジ	Screw 9/64"(3.57)×40/6.5
36	138A	1	1	1	1	1	糸ユルメビン	Tension releasing pin
37	140	2	2	2	2	2	針板締ネジ	Screw 11/64"(4.37)×40
38	141	1	1	1	1	1	滑り板	Bed slide
39	142	1	1	1	1	1	滑り板バネ	Bed slide spring
40	143	2	2	2	2	2	滑り板バネ締ネジ	Screw 3/32"(2.38)×56
41	144	1	1	1	1	1	ナット	Nut 7/32"(5.56)×32
42	145	1	1	1	1	1	支エ	Holder
43	146	2	2	2	2	2	締ネジ	Screw 3/16"(4.76)×28/12
44	701	1					アームベット	Arm bed
45	701a		1				アームベット	Arm bed
46	701b			1			アームベット	Arm bed
47	701c				1		アームベット	Arm bed
48	701d					1	アームベット	Arm bed
49	702	1			1		面板	Face plate
50	702a		1	1		1	面板	Face plate
51	703	1					側板(大)	Arm side cover (Large)
52	703a		1	1			側板(大)	Arm side cover (Large)
53	703b				1		側板(大)	Arm side cover (Large)
54	703c					1	側板(大)	Arm side cover (Large)
55	704	1			1		側板(小)	Arm side cover (Small)
56	704a		1	1		1	側板(小)	Arm side cover (Small)
57	705	1			1		針板	Needle plate
58	705a		1	1		1	針板	Needle plate
59		1	1	1			カバー	Cover (For cam)
60		2	2	2			ネジ	Screw

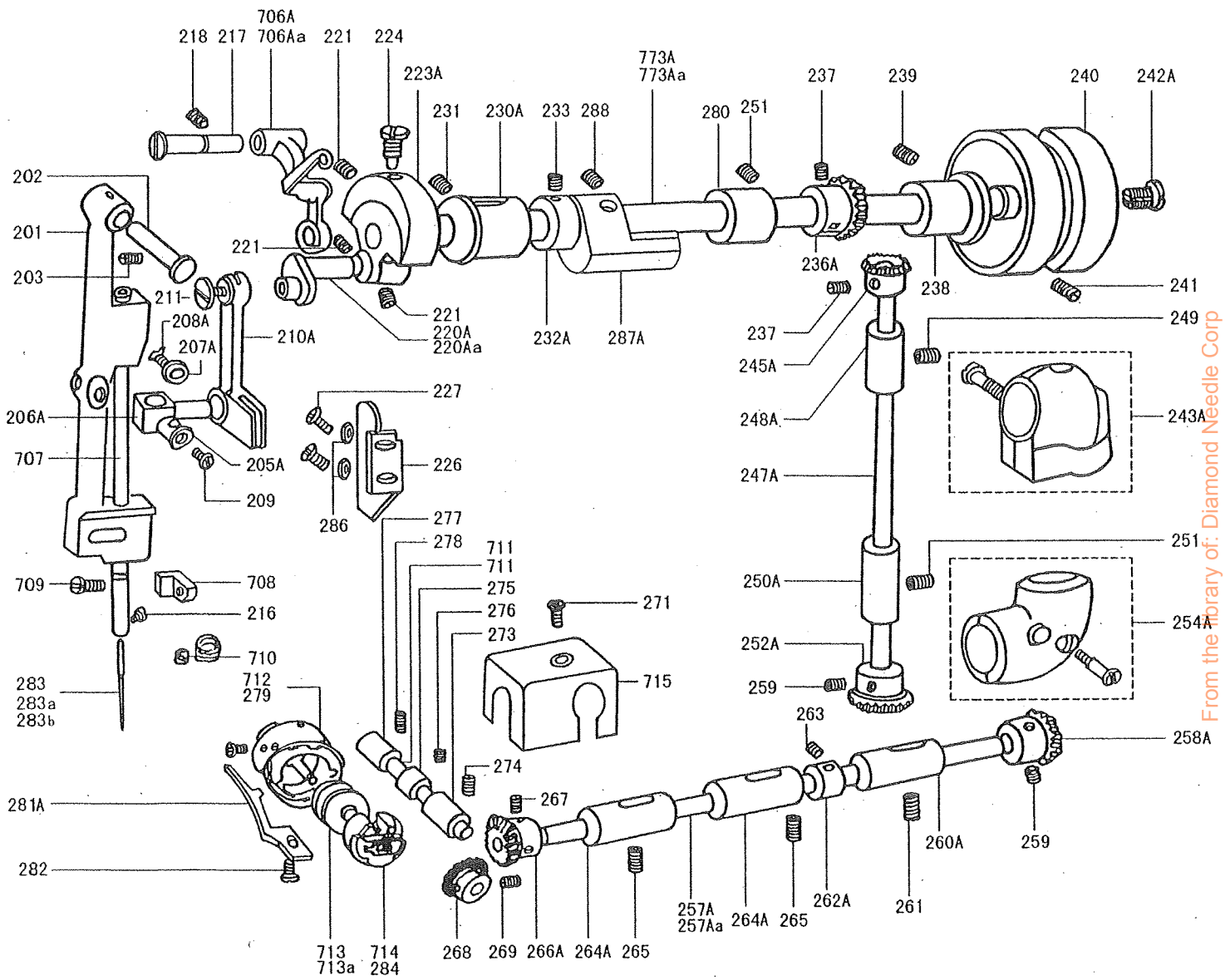

From the library of: Diamond Needle Corp

SEWING MECHANISM

NO	部品番号 PART NO	146RB- *A-1	199RB- *A-1	199R- *A-1	146RBL- *A-1	199RBL- *A-1	品名	PARTS NAME
1	201	1	1	1	1	1	針棒桿	Needle bar frame
2	202	1	1	1	1	1	針棒桿止ビン	Hinge pin
3	203	1	1	1	1	1	針棒桿止ビン止ネジ	Screw 11/64"(4.37)×40/6
4	205A	1	1	1	1	1	針棒抱	Needle bar connecting stud bushing
5	206A	1	1	1	1	1	針棒抱支エ	Needle bar connecting stud
6	207A	1	1	1	1	1	針棒抱支エ座	Washer
7	208A	1	1	1	1	1	針棒抱支エ座締ネジ	Screw 11/64"(4.37)×40
8	209	1	1	1	1	1	針棒止ネジ	Screw 11/64"(4.37)×40/5.5
9	210A	1	1	1	1	1	針棒クランクロット	Needle bar connecting link
10	211	1	1	1	1	1	針棒クランク皿ネジ	Screw
11	216	1	1	1	1	1	針止ネジ	Screw
12	217	1	1	1	1	1	天秤支エ軸	Take-up lever link hinge pin
13	218	1	1	1	1	1	天秤支エ軸止ネジ	Screw 15/64"(5.95)×28/10
14	220A	1	1		1	1	針棒クランク	Take-up crank
15	220Aa			1			針棒クランク	Take-up crank
16	221	3	3	3	3	3	針棒クランク止ネジ(大)	Screw 1/4"(6.35)×40/6
17	223A	1	1	1	1	1	天秤クランク	Needle crank
18	224	1	1	1	1	1	天秤クランク止ネジ(大)	Screw (Large)
19	226	1	1	1	1	1	針棒クランクロット案内板	Needle bar connecting link guide plate
20	227	2	2	2	2	2	止ネジ	Screw 9/64"(3.57)×40/6.5
21	230A	1	1	1	1	1	上軸メタル(左)	Arm shaft bushing (Left)
22	231	1	1	1	1	1	上軸メタル(左)止ネジ	Screw 15/64"(5.95)×28/10
23	232A	1	1	1	1	1	上軸カラー	Arm shaft collar
24	233	2	2	2	2	2	上軸カラー止ネジ	Screw
25	236A	1	1	1	1	1	上軸歯車	Arm shaft (Horizontal) lever gear
26	237	4	4	4	4	4	上軸歯車止ネジ	Screw 1/4"(6.35)×40/7
27	238	1	1	1	1	1	上軸メタル(右)	Arm shaft bushing (Right)
28	239	1	1	1	1	1	上軸メタル(右)止ネジ	Screw 15/64"(5.95)×28/10
29	240	1	1	1	1	1	ハズミ車	Hand weel
30	241	2	2	2	2	2	ハズミ車止ネジ	Screw 15/64"(5.95)×28/16
31	242A	1	1	1	1	1	ハズミ車締ネジ	Positioning screw 11/32"(8.73)×28
32	243A	1	1	1	1	1	上歯車ケース(組)	Gear case complete
33	245A	1	1	1	1	1	立軸歯車(上)	Upright shaft gear (Upper)
34	247A	1	1	1	1	1	立軸	Upright shaft
35	248A	1	1	1	1	1	立軸メタル(上)	Upright shaft bushing (Upper)
36	249	1	1	1	1	1	立軸メタル(上)止ネジ	Screw 15/64"(5.95)×28/10
37	250A	1	1	1	1	1	立軸メタル(下)	Upright shaft bushing (Lower)
38	251	1	1	1	2	2	立軸メタル(下)止ネジ	Screw 15/64"(5.95)×28/10
39	252A	1	1	1	1	1	立軸歯車(下)	Upright shaft gear (Lower)
40	254A	1	1	1	1	1	下歯車ケース(組)	Upright shaft gear case complete
41	257A	1	1	1			下軸	Hook drive shaft
42	257Aa				1	1	下軸	Hook drive shaft
43	258A	1	1	1	1	1	下軸歯車(右)	Hook drive shaft gear (Right)
44	259	4	4	4	4	4	下軸歯車(右)止ネジ	Screw 1/4"(6.35)×40/7
45	260A	1	1	1	1	1	下軸メタル(右)(組)	Hook drive shaft bushing (Right) complete
46	261	1	1	1	1	1	下軸メタル(右)止ネジ	Screw 15/64"(5.95)×28/7
47	262A	1	1	1	1	1	下軸カラー	Hook drive shaft collar
48	263	2	2	2	2	2	下軸カラー止ネジ	Screw 15/64"(5.95)×28/4.5
49	264A	1	1	1	2	2	下軸メタル(左)(組)	Hook drive shaft bushing (Left) complete
50	265	1	1	1	2	2	下軸メタル(左)止ネジ	Screw 15/64"(5.95)×28/7
51	266A	1	1	1	1	1	下軸歯車(左)	Hook drive shaft gear (Left)
52	267	2	2	2	2	2	下軸歯車(左)止ネジ	Screw 1/4"(6.35)×40/7
53	268	1	1	1	1	1	釜軸歯車	Hook shaft gear
54	269	2	2	2	2	2	釜軸歯車止ネジ	Screw 11/64"(4.37)×40/6
55	271	1	1	1	1	1	釜軸歯車ケース止ネジ	Screw 9/64"(3.57)×40/6.5
56	273	1	1	1	1	1	釜軸メタル(前)	Hook shaft bushing (Front)
57	274	2	2	2	2	2	釜軸メタル(前)止ネジ	Screw 15/64"(5.95)×28/4.5
58	275	1	1	1	1	1	釜軸メタルカラー	Hook shaft bushing collar
59	276	2	2	2	2	2	釜軸メタルカラー止ネジ	Screw 11/64"(4.37)×40/3.8

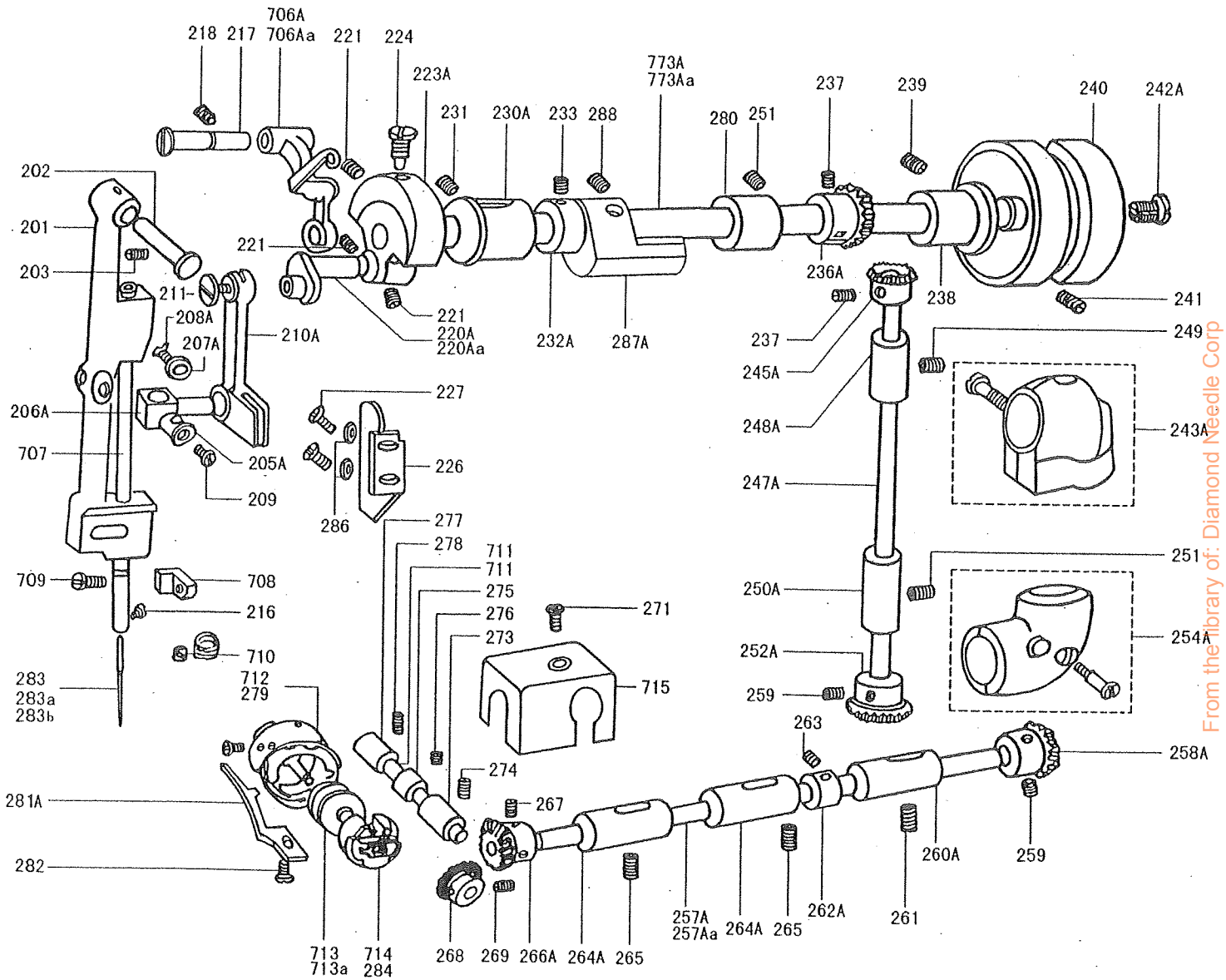

From the library of: Diamond Needle Corp

SEWING MECHANISM

NO	部品番号 PART NO	146RB- *A-1	199RB- *A-1	199R- *A-1	146RBL- *A-1	199RBL- *A-1	品名	PARTS NAME
60	277	1	1	1	1	1	釜軸メタル(後)	Hook shaft bushing (Rear)
61	278	1	1	1	1	1	釜軸メタル(後)止ネジ	Screw 15/64"(5.95)×28/7
62	279			1			釜	Hook
63	280				1	1	上軸メタル(中)	Arm shaft bushing (Middle)
64	281A	1	1	1	1	1	内釜止	Bobbin case position bracket
65	282	1	1	1	1	1	内釜止止ネジ	Screw 11/64"(4.37)×40/10
66	283	1			1		針	Needle (DP×17 18#)
67	283a		1			1	針	Needle(DP×5 16#)
68	283b			1			針	Needle(DP×5 14#)
69	284			1			ボビンケース	Bobbin case
70	286	2	2	2	2	2	ワッシャー	Washer
71	287A		1	1		1	バランス	Balance weight
72	288		2	2		2	ネジ	Screw 15/64"(5.95)×28/10
73	706A	1	1		1	1	リンク天秤(組)	Take up lever complete
74	706Aa			1			リンク天秤(組)	Take up lever complete
75	707	1	1	1	1	1	針棒	Needle bar
76	708	1	1	1	1	1	針棒桿押エ	Needle bar frame holder
77	709	1	1	1	1	1	針棒桿押エ締ネジ	Screw 9/64"(3.57)×40/6.5
78	710	1	1	1	1	1	針棒糸掛	Needle bar thread guide
79	711	1	1		1	1	釜軸	Hook shaft
	711a			1			釜軸	Hook shaft
80	712	1	1		1	1	釜	Hook
81	713	1	1		1	1	ボビン	Bobbin
82	713a			1			ボビン	Bobbin
83	714	1	1		1	1	ボビンケース	Bobbin case
84	715	1	1	1	1	1	釜軸歯車ケース	Hook shaft gear case
85	773A	1	1	1			上軸	Arm shaft
86	773Aa				1	1	上軸	Arm shaft

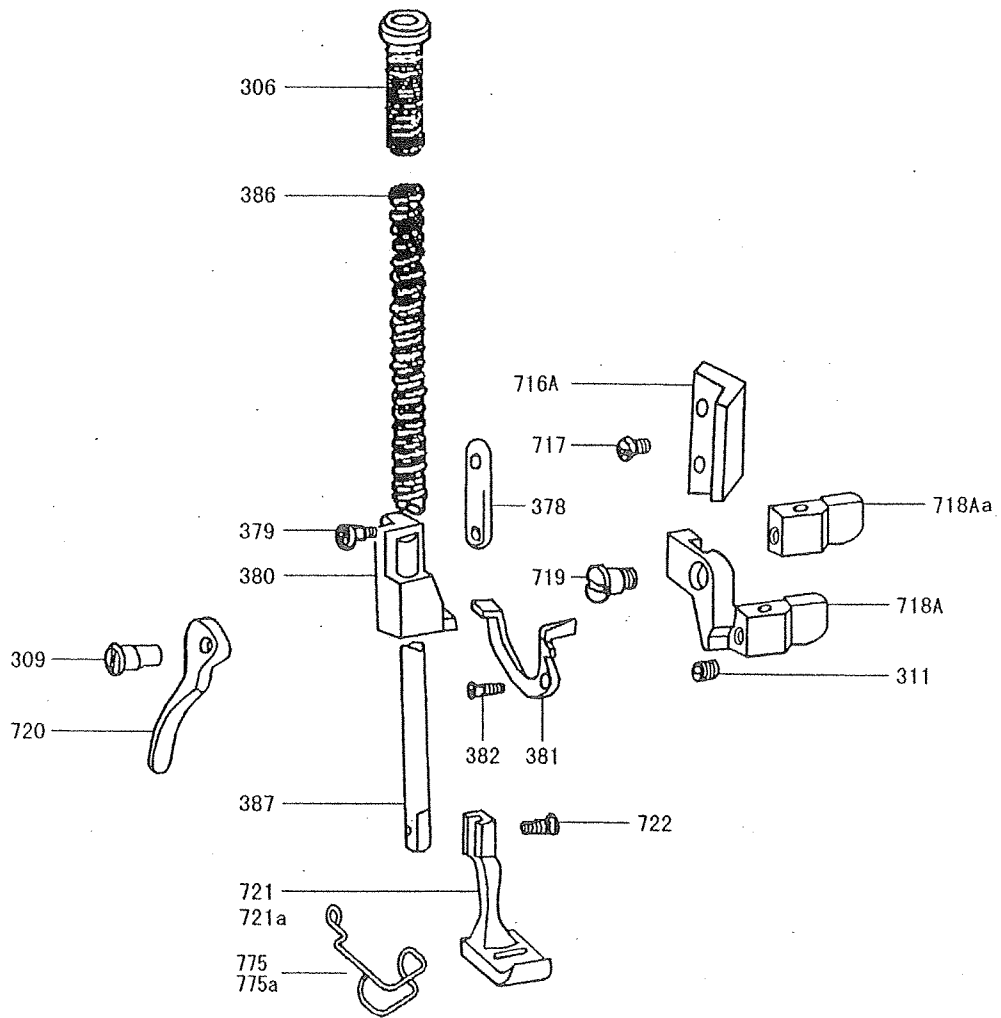

押え機構

PRESSER FOOT MECHANISM

NO	部品番号 PART NO	146RB- *A-1	199RB- *A-1	199R- *A-1	146RBL- *A-1	199RBL- *A-1	品名	PARTS NAME
1	306	1	1	1	1	1	押エ調節ネジ	Screw
2	309	1	1	1	1	1	押エ上ゲネジ	Screw 15/64"(5.95)×28/8
3	311	1	1	1	1	1	押エ棒抱止ネジ	Screw 15/64"(5.95)×28/7
4	378	1	1	1	1	1	引上板	Lifting lever link
5	379	1	1	1	1	1	引上板止ネジ	Screw 3/16"(4.76)×32
6	380	1	1	1	1	1	押エ棒ツリ	Presser bar lifting and releasing lever bracket
7	381	1	1	1	1	1	糸ユルメレバー	Tension releasing lever
8	382A	1	1	1	1	1	糸ユルメレバー締ネジ	Screw 11/64"(4.37)×40/8
9	386	1	1	1	1	1	押エバネ	Spring
10	387	1	1	1	1	1	押エ棒	Presser bar
11	716A	1			1		押エ棒抱ガイド	Presser bar guide
12	717	2			2		押エ棒抱ガイド締ネジ	Screw 9/64"(3.57)×40/8
13	718A	1			1		押エ棒抱	Presser bar holder
14	718Aa		1	1		1	押エ棒抱	Presser bar holder
15	719	1			1		押エ棒抱結合ネジ	Screw
16	720	1	1	1	1	1	押エ上ゲ	Presser bar lifter
17	721	1			1		中押金	Presser foot (Inside)
18	721a		1	1		1	押金	Presser foot
19	722	1	1	1	1	1	中押金締ネジ	Screw 9/64"(3.57)×40/8
20	775	1			1		フィンガーガード	Finger guard
21	775a		1	1		1	フィンガーガード	Finger guard

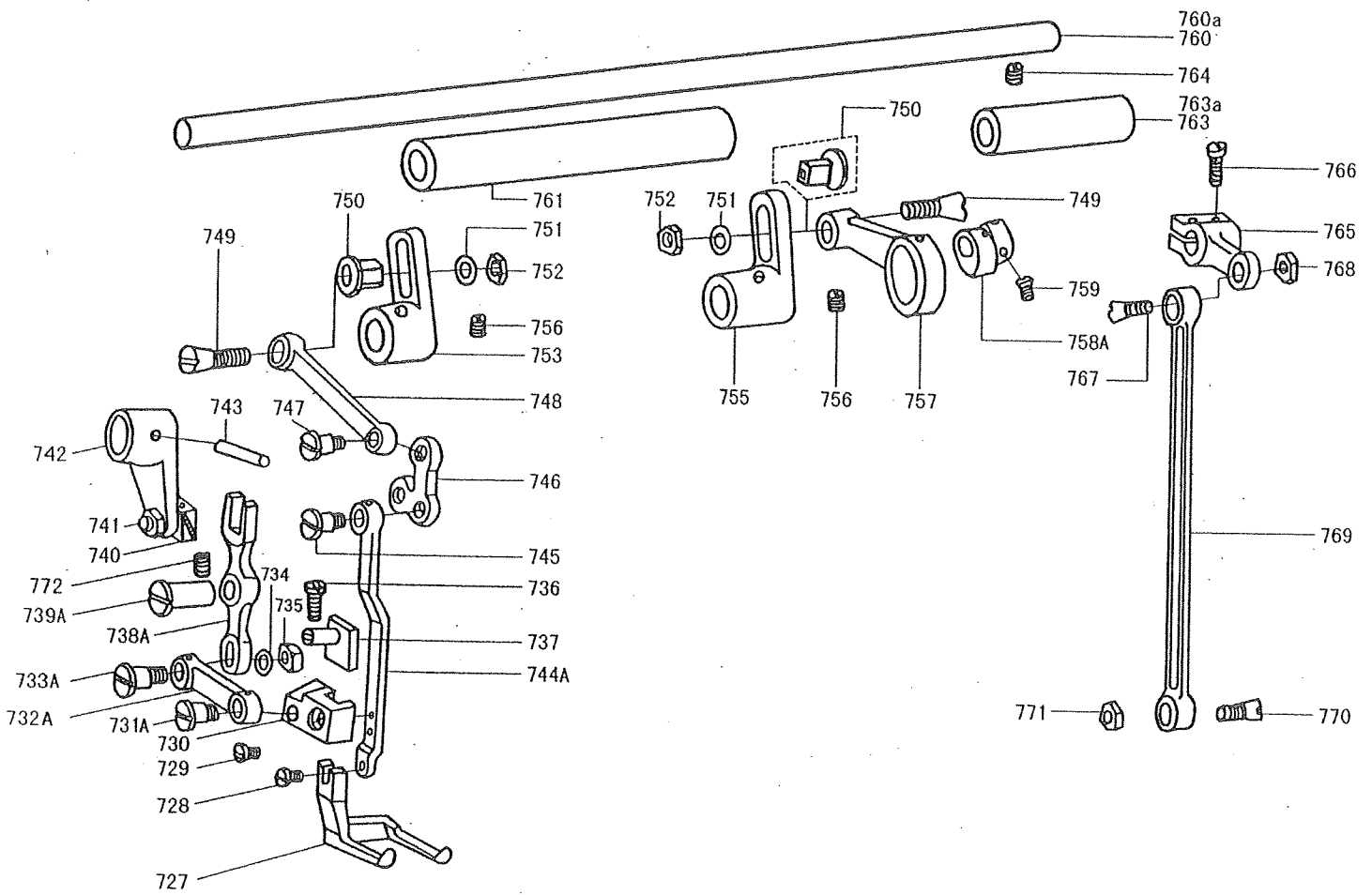

From the library of: Diamond Needle Corp

UPPER FEED MECHANISM

NO	部品番号 PART NO	146RB- *A-1	146RBL- *A-1	品名	PARTS NAME
1	727	1	1	外押エ金	Walking foot
2	728	1	1	外押エ金締ネジ	Walking foot screw 9/64"(3.57)×40/8
3	729	1	1	押エ前後ロット受止ネジ	Screw 11/64"(4.37)×40/7
4	730	1	1	押エ前後ロット受	Feed arm
5	731A	1	1	押エ前後ロット受段ネジ	Screw 1/4"(6.35)×40
6	732A	1	1	前後メガネ	Walking foot connecting link
7	733A	1	1	前後ロット段ネジ	Screw 15/64"(5.95)×28
8	734	1	1	前後ロット段ネジ座金	Washer
9	735	1	1	前後ロット段ネジナット	Nut 15/64"(5.95)×28
10	736	1	1	外押エ土台受結合ネジ止ネジ	Screw 9/64"(3.57)×40/8
11	737	1	1	外押エ土台受	Guide
12	738A	1	1	前後又	Feed connecting lever
13	739A	1	1	前後又ピン	Hinged pin
14	740	1	1	前後又角玉	Feed connecting slick block complete
15	741	1	1	前後又角玉ナット	Nut 9/32"(7.14)×28
16	742	1	1	中軸グルマ	Feed driving shaft crank
17	743	1	1	中軸グルマノックピン	Knock pin
18	744A	1	1	外押エ土台	Walking foot guide link
19	745	1	1	押エ上下連結桿結合ネジ	Screw
20	746	1	1	押エ上下連結桿	Bell crank
21	747	1	1	上下メガネ結合ネジ	Screw
22	748	1	1	上下メガネ	Feed lifting rock shaft link
23	749	2	2	テーバーネジ	Taper screw 9/32"(7.14)×28
24	750	2	2	振子グルマコマ	Bushing
25	751	2	2	テーバーネジ座金	Washer
26	752	2	2	テーバーネジナット	Nut 9/32"(7.14)×28
27	753	1	1	振子グルマ(小)	Feed lifting rock shaft crank (Small)
28	755	1	1	振子グルマ(大)	Feed lifting rock shaft crank (Big)
29	756	4	4	振子グルマ(大)止ネジ	Screw 15/64"(5.95)×28/4.5
30	757	1	1	カムロット	Feed connecting crank rod
31	758A	1	1	上下カム	Feed lifting eccentric
32	759	2	2	上下カム止ネジ	Screw 15/64"(5.95)×28/14
33	760	1		中軸	Feed driving shaft
34	760a		1	中軸	Feed driving shaft
35	761	1	1	振子軸	Feed lifting rock shaft
36	763	1		中軸後メタル	Feed driving shaft bushing (Rear)
37	763a		1	中軸後メタル	Feed driving shaft bushing (Rear)
38	764	1	1	中軸後メタル止ネジ	Screw 15/64"(5.95)×28/7
39	765	1	1	中軸腕	Feed driving shaft crank
40	766	2	2	中軸腕締ネジ	Screw 11/64"(4.37)×40/12
41	767	1	1	中軸腕テーバーピン	Taper screw
42	768	1	1	中軸腕テーバーピンナット	Nut 9/32"(7.14)×28
43	769	1	1	前後ロット	Feed driving connecting link
44	770	1	1	前後ロットテーバーピン	Taper screw
45	771	1	1	前後ロットテーバーピンナット	Nut 9/32"(7.14)×28
46	772	1	1	前後又ピン止ネジ	Screw 15/64"(5.95)×28/8

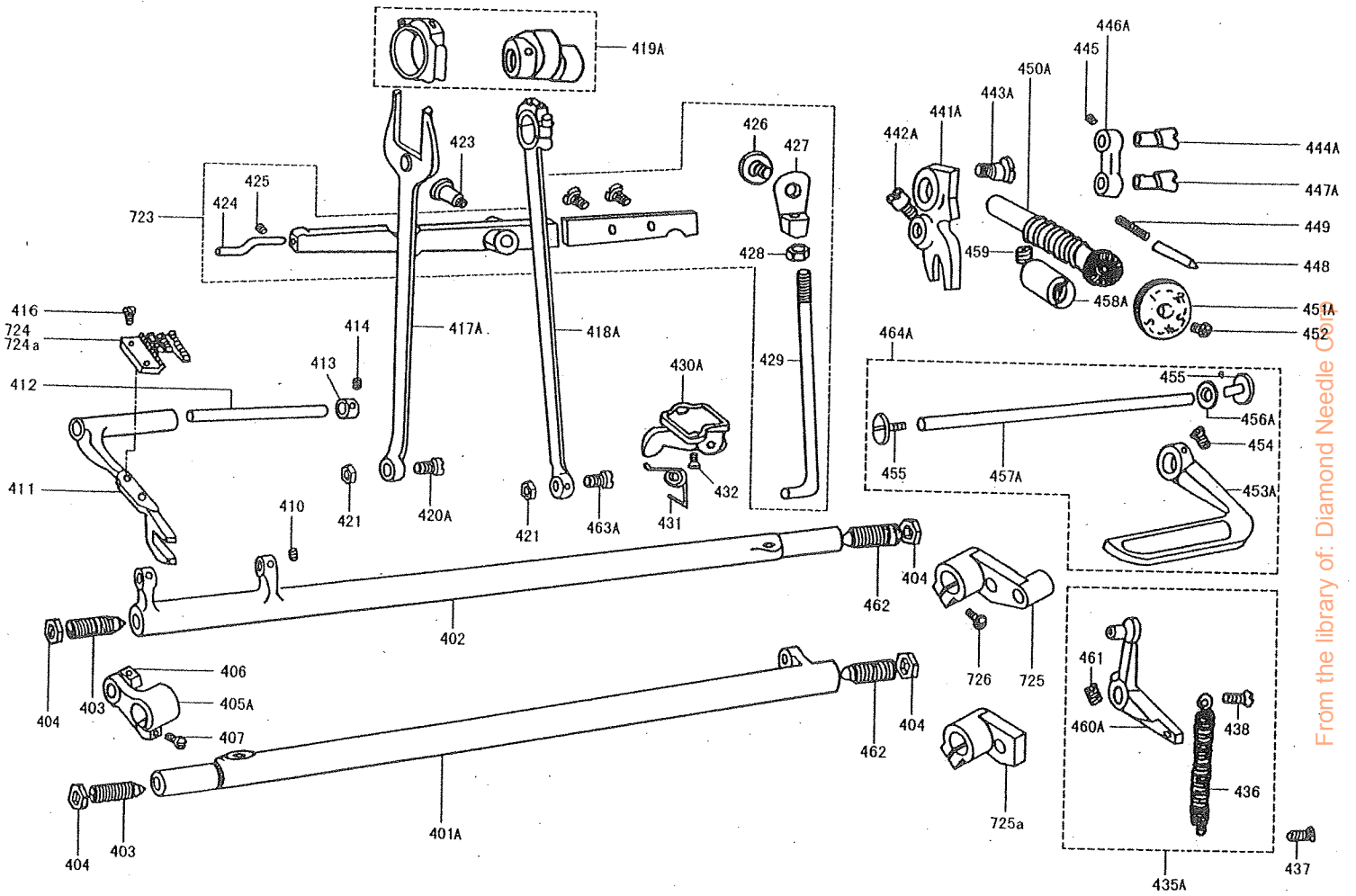

From the library of: Diamond Needle Co.

STITCH LENGTH REGULATOR & LOWER FEED MECHANISM

NO	部品番号 PART NO	146RB- *A-1	199RB- *A-1	199R- *A-1	品名	PARTS NAME
1	401A	1	1	1	上下送り軸	Feed lifting rock shaft
2	402	1	1	1	水平送り軸	Feed rock shaft
3	403	2	2	2	送り軸ネジセンター	Screw 3/8"(9.53)×28
4	404	4	4	4	送り軸ネジセンターナット	Nut 3/8"(9.53)×28
5	405A	1	1	1	上下送り腕	Feed lifting rock shaft crank
6	406	1	1	1	上下送りコロ	Feed lifting rock shaft roller
7	407	1	1	1	上下送り腕締ネジ	Screw 11/64"(4.37)×40/12
8	410	2	2	2	送り台軸止ネジ	Screw 11/64"(4.37)×40/3.8
9	411	1	1	1	送り台	Feed bar
10	412	1	1	1	送り台軸	Feed bar shaft
11	413	1	1	1	送り台軸カラー	Feed bar shaft collar
12	414	1	1	1	送り台軸カラー止ネジ	Screw
13	416	2	2	2	送歯締ネジ	Screw
14	417A	1	1	1	二又ロット	Feed forked connection
15	418A	1	1	1	クランクロット	Feed lifting rock shaft connecting rod
16	419A	1	1	1	送りカム(組)	Feed cam complete
17	420A	1	1	1	ネジ	Hinge screw 9/32"(7.14)28
18	421	2	2	2	テーパネジナット	Nut 9/32"(7.14)28
19	423	1	1	1	ヒザ上ゲテコ締ネジ	Hinge screw 5/16"(7.94)×24
20	424	1	1	1	ヒザ上ゲテコピン	Knee lifter lifting lever pin
21	425	1	1	1	ヒザ上ゲテコピン止ネジ	Screw 15/64"(5.95)×28/4.5
22	426	1	1	1	テコ接手ヒンヂネジ	Hinge screw
23	427	1	1	1	テコ接手	Knee lifter lifting lever connecting rod joint
24	428	1	1	1	ヒザ上ゲ引棒ナット	Nut 3/16"(4.76)×32
25	429	1	1	1	ヒザ上ゲ引棒	Knee lifter lifting lever connecting rod
26	430A	1	1	1	ヒザ上ゲ台	Knee lifter bell crank complete
27	431	1	1	1	ヒザ上ゲバネ	Knee lifter bell crank spring
28	432	2	2	2	ヒザ上ゲ台締ネジ	Screw 11/64"(4.37)×40/12
29	435A	1	1	1	送り調節腕組立	Stitch length regulator complete
30	436	1	1	1	送り調節レバー引バネ	Spring
31	437	1	1	1	送り調節レバー止ネジ(下)	Screw (Lower) 9/64"(3.57)×40/6.5
32	438	1	1	1	送り調節レバー止ネジ(上)	Screw (Upper) 9/64"(3.57)×40/8
33	441A	1	1	1	又付送り調節器	Feed regulator (Forked)
34	442A	1	1	1	送りリンク止ネジ	Screw 15/64"(5.95)×28/10
35	443A	1	1	1	送り調節器止ネジ	Screw 9/32"(7.14)×28
36	444A	1	1	1	送りリンク軸(一)	Hinge stud
37	445	1	1	1	ネジ	Screw 15/64"(5.95)×28/10
38	446A	1	1	1	送りリンク	Feed connecting link
39	447A	1	1	1	送りリンク軸(二)	Hinge stud
40	448	1	1	1	目盛り位置決メピン	Feed regulating dial lock pin
41	449	1	1	1	目盛り位置決メバネ	Spring
42	450A	1	1	1	送り調節ネジ	Feed regulating stud
43	451A	1	1	1	送り目盛板	Feed regulating dial
44	452	1	1	1	送り目盛締ネジ	Screw 3/16"(4.76)×28/8
45	464A	1	1	1	送り調節レバー(組)	Feed reverse lever complete
46	453A	1	1	1	送り調節レバー	Feed reverse lever
47	454	2	2	2	送り調節レバー止ネジ	Screw 15/64"(5.95)×28/10
48	455	2	2	2	送り調節レバー軸締ネジ	Screw 3/16"(4.76)×28/6.5
49	456A	2	2	2	送り調節レバー軸座金	Spring washer
50	457A	1	1	1	送り調節レバー軸	Feed reverse lever shaft
51	458A	1	1	1	送り調節ネジメタル	Bushing for stitch length regulator screw
52	459	1	1	1	送り調節ネジメタル止ネジ	Screw 15/64"(5.95)×28/8
53	460A	1	1	1	送り調節器玉台	Stitch length regulator complete
54	461	2	2	2	送り調節器玉台止ネジ	Screw 15/64"(5.95)×28/7
55	462	2	2	2	送り軸ネジセンター	Screw 3/8"(9.53)×28
56	463A	1	1	1	ネジ	Screw 9/32"(7.14)×28
57	723A	1	1	1	ヒザ上ゲ(組)	Knee lifter lifting lever complete
58	724	1			送り歯	Feed dog
59	724a		1	1	送り歯	Feed dog
60	725	1			水平送り腕	Feed rock shaft crank
61	725a		1	1	水平送り腕	Feed rock shaft crank
62	726	2	2	2	水平送り腕締ネジ	Screw 11/64"(4.37)×40/12

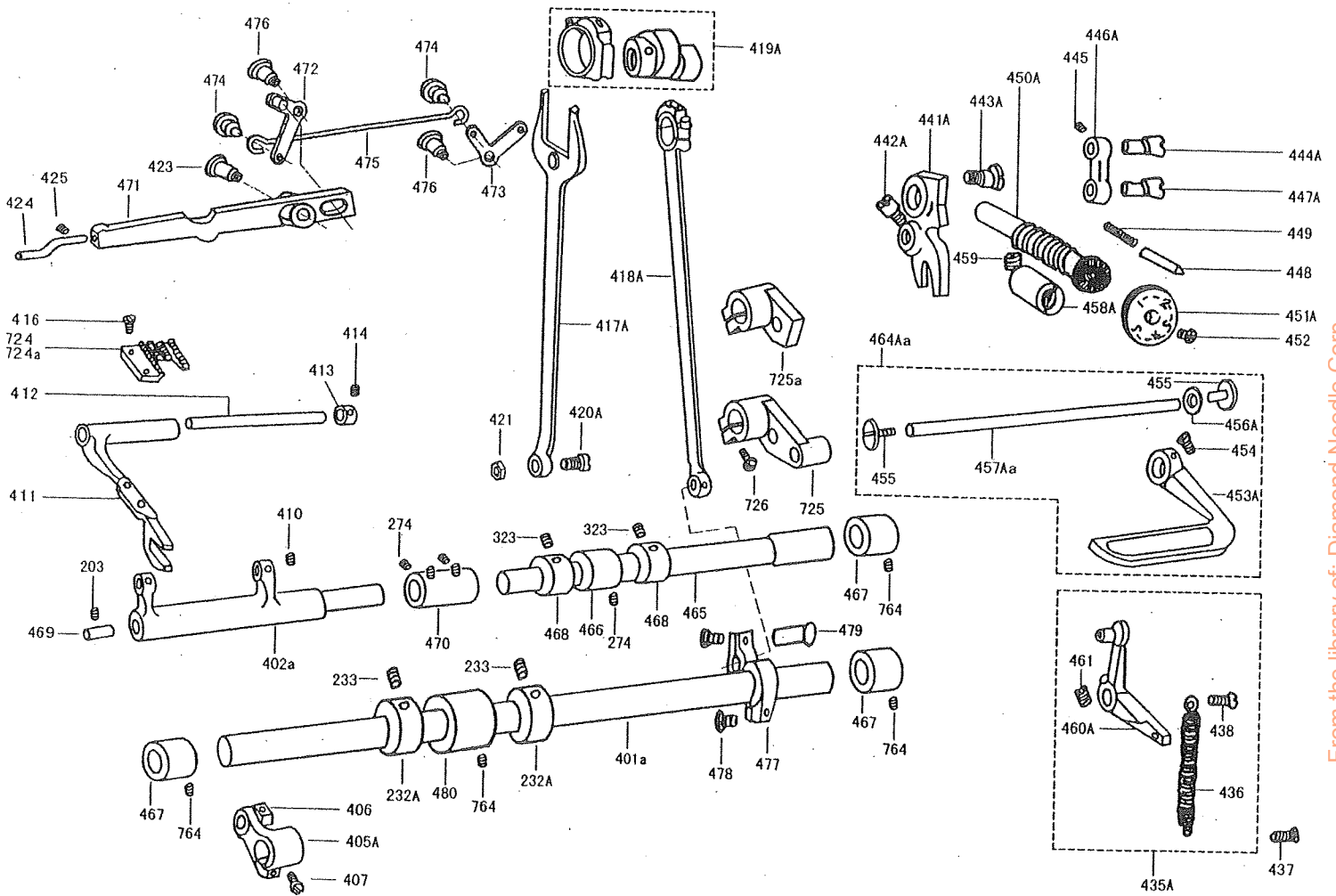

From the library of: Diamond Needle Corp

縫目調節、下送り機構

STITCH LENGTH REGULATOR & LOWER FEED MECHANISM

NO	部品番号 PART NO	146RBL- *A-1	199RBL- *A-1	品名	PARTS NAME
1	203	1	1	止ネジ	Set screw
2	232A	2	2	カラー	Collar
3	233	4	4	止ネジ	Set screw
4	274	4	4	止ネジ	Set screw
5	323	4	4	止ネジ	Set screw
6	401a	1	1	上下送り軸	Feed lifting rock shaft
7	402a	1	1	水平送り腕	Feed rock shaft crank
8	405A	1	1	上下送り腕	Feed lifting rock shaft crank
9	406	1	1	上下送りコロ	Feed lifting rock shaft roller
10	407	1	1	上下送り腕締ネジ	Screw 11/64"(4.37)×40/12
11	410	2	2	送り台軸止ネジ	Screw 11/64"(4.37)×40/3.8
12	411	1	1	送り台	Feed bar
13	412	1	1	送り台軸	Feed bar shaft
14	413	1	1	送り台軸カラー	Feed bar shaft collar
15	414	1	1	送り台軸カラー止ネジ	Screw
16	416	2	2	送歯締ネジ	Screw
17	417A	1	1	二又ロット	Feed forked connection
18	418A	1	1	クランクロット	Feed lifting rock shaft connecting rod
19	419A	1	1	送りカム(組)	Feed cam complete
20	420A	1	1	ネジ	Hinge screw 9/32"(7.14)28
21	421	1	1	テーパネジナット	Nut 9/32"(7.14)28
22	423	1	1	ヒザ上ゲテコ締ネジ	Hinge screw 5/16"(7.94)×24
23	424	1	1	ヒザ上ゲテコピン	Knee lifter lifting lever pin
24	425	1	1	ヒザ上ゲテコピン止ネジ	Screw 15/64"(5.95)×28/4.5
25	435A	1	1	送り調節腕組立	Stitch length regulator complete
26	436	1	1	送り調節レバー引バネ	Spring
27	437	1	1	送り調節レバー止ネジ(下)	Screw (Lower) 9/64"(3.57)×40/6.5
28	438	1	1	送り調節レバー止ネジ(上)	Screw (Upper) 9/64"(3.57)×40/8
29	441A	1	1	又付送り調節器	Feed regulator (Forked)
30	442A	1	1	送りリンク止ネジ	Screw 15/64"(5.95)×28/10
31	443A	1	1	送り調節器止ネジ	Screw 9/32"(7.14)×28
32	444A	1	1	送りリンク軸(一)	Hinge stud
33	445	1	1	ネジ	Screw 15/64"(5.95)×28/10
34	446A	1	1	送りリンク	Feed connecting link
35	447A	1	1	送りリンク軸(二)	Hinge stud
36	448	1	1	目盛り位置決メピン	Feed regulating dial lock pin
37	449	1	1	目盛り位置決メバネ	Spring
38	450A	1	1	送り調節ネジ	Feed regulating stud
39	451A	1	1	送り目盛板	Feed regulating dial
40	452	1	1	送り目盛締ネジ	Screw 3/16"(4.76)×28/8
41	464Aa	1	1	送り調節レバー(組)	Feed reverse lever complete
42	453A	1	1	送り調節レバー	Feed reverse lever
43	454	2	2	送り調節レバー止ネジ	Screw 15/64"(5.95)×28/10
44	455	2	2	送り調節レバー軸締ネジ	Screw 3/16"(4.76)×28/6.5
45	456A	2	2	送り調節レバー軸座金	Spring washer
46	457Aa	1	1	送り調節レバー軸	Feed reverse lever shaft
47	458A	1	1	送り調節ネジメタル	Bushing for stitch length regulator screw
48	459	1	1	送り調節ネジメタル止ネジ	Screw 15/64"(5.95)×28/8
49	460A	1	1	送り調節器玉台	Stitch length regulator complete
50	461	2	2	送り調節器玉台止ネジ	Screw 15/64"(5.95)×28/7
51	465	1	1	水平送り軸	Feed rock shaft
52	466	1	1	送り軸メタル(左)	Bushing(Left)
53	467	3	3	メタル	Bushing
54	468	2	2	カラー	Collar
55	469	1	1	軸	Shaft
56	470	1	1	クラッチ	Clutch
57	471	1	1	膝上グレバー	Knee lifter lever
58	472	1	1	膝上グレバー(左)	Knee lifter lever(Left)
59	473	1	1	膝上グレバー(右)	Knee lifter lever(Right)
60	474	2	2	段ネジ	Stud screw
61	475	1	1	膝上グレンカン	Knee lifter connector
62	476	2	2	段ネジ	Stud screw

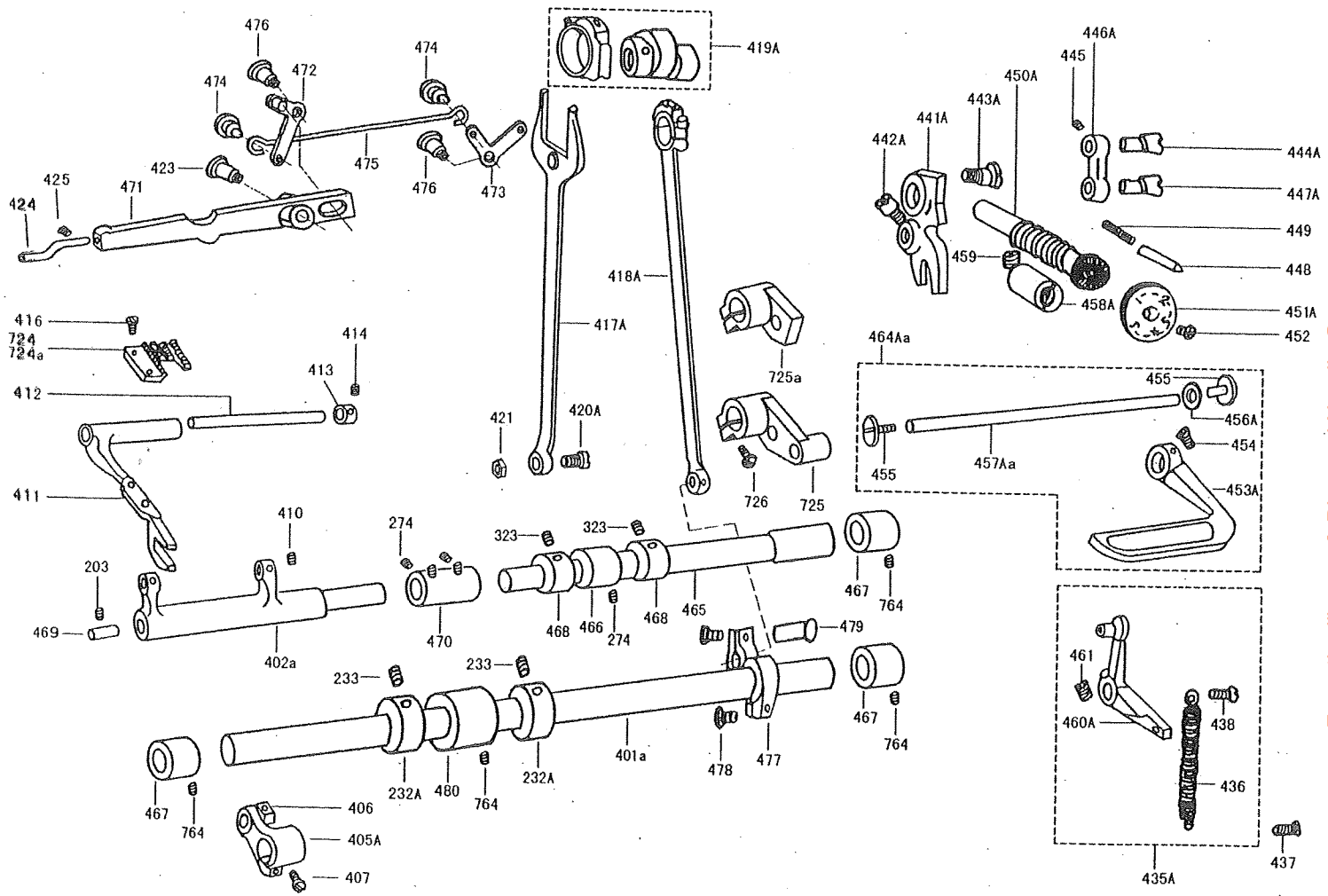

From the library of: Diamond Needle Corp

STITCH LENGTH REGULATOR & LOWER FEED MECHANISM

NO	部品番号 PART NO	146RBL- *A-1	199RBL- *A-1	品名	PARTS NAME
63	477	1	1	上下送り軸腕(右)	Feed lifting rock shaft crank(Right)
64	478	2	2	マルヒラネジ	Screw
65	479	1	1	段付軸	Set pin
66	480	1	1	メタル	Bushing
67	724	1		送り歯	Feed dog
68	724a		1	送り歯	Feed dog
69	725	1		水平送り腕	Feed rock shaft crank
70	725a		1	水平送り腕	Feed rock shaft crank
71	726	2	2	水平送り腕締ネジ	Screw 11/64"(4.37)×40/12
72	764	4	4	止ネジ	Set screw

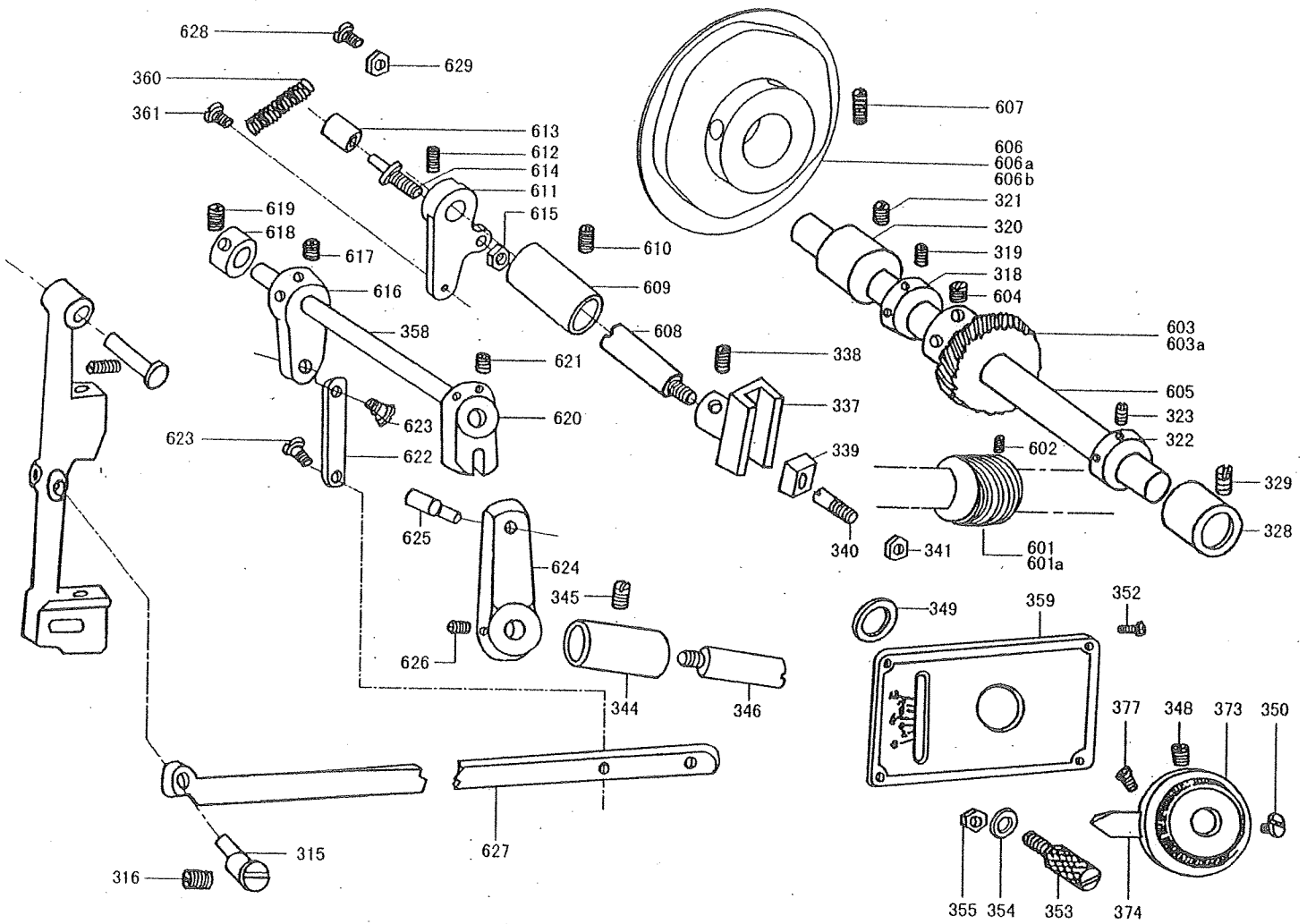

From the library of: Diamond Needle Corp

NEEDLE ROCK MECHANISM

NO	部品番号 PART NO	146RB- *A-1	199RB- *A-1	199R- *A-1	146RBL- *A-1	199RBL- *A-1	品名	PARTS NAME
1	315	1	1	1	1	1	エキセンビン	Eccentric stud
2	316	1	1	1	1	1	エキセンビン止ネジ	Screw 1/4"(6.35)×40/7
3	318	1	1	1	1	1	針振カム軸カラー(後)	Collar (Rear)
4	319	2	2	2	2	2	針振カム軸カラー(後)止ネジ	Screw 11/64"(4.37)×40/3.8
5	320	1	1	1	1	1	針振カム軸メタル(後)	Bushing (Rear)
6	321	1	1	1	1	1	針振カム軸メタル(後)止ネジ	Screw 15/64"(5.95)×28/7
7	322	1	1	1	1	1	針振カム軸カラー(前)	Collar (Front)
8	323	2	2	2	2	2	針振カム軸カラー(前)止ネジ	Screw
9	328	1	1	1	1	1	針振カム軸メタル(前)	Bushing (Front)
10	329	1	1	1	1	1	針振カム軸メタル(前)止ネジ	Screw 15/64"(5.95)×28/7
11	337	1	1	1	1	1	針振調節器	Zig-zag regulator
12	338	1	1	1	1	1	針振軸締ネジ	Screw 15/64"(5.95)×28/8
13	339	1	1	1	1	1	針振調節器玉	Zig-zag regulator slide block
14	340	1	1	1	1	1	針振調節器玉ピン	Stud
15	341	1	1	1	1	1	玉ピン締ナット	Nut 9/32"(7.14)×28
16	344	1	1	1	1	1	針振クランクメタル	Zig-zag regulator bushing
17	345	1	1	1	1	1	針振クランクメタル止ネジ	Screw 15/64"(5.95)×28/7
18	346	1	1	1	1	1	針振クランク軸	Zig-zag regulator stud
19	348	1	1	1	1	1	針振調節ツマミ止ネジ	Screw 15/64"(5.95)×28/14
20	349	1	1	1	1	1	針振ダイヤル座金	Spring washer
21	350	1	1	1	1	1	中出調節ツマミ締ネジ	Screw 3/16"(4.76)×28/6.5
22	352	4	4	4	4	4	針振目盛板止ネジ	Screw 9/64"(3.57)×40/7
23	353	2	2	2	2	2	針振ストッパー	Stopper 3/16"(4.76)×32
24	354	1	1	1	1	1	針振ストッパーワッシャー	Washer
25	355	1	1	1	1	1	針振ストッパー止ナット	Nut 3/16"(4.76)×32
26	358	1	1	1	1	1	針振軸	Needle vibrating shaft
27	359	1	1	1	1	1	針振目盛板	Zig-zag indicator plate
28	360	1	1	1	1	1	バネ	Spring
29	361	1	1	1	1	1	ネジ	Screw 9/64"(3.57)×40/6.5
30	373	1	1	1	1	1	中出調節ツマミ	Dial
31	374	1	1	1	1	1	針振指針	Index finger
32	377	1	1	1	1	1	針振指針止ネジ	Screw 11/64"(4.37)×40
33	601	1	1	1	1	1	針振動ギア	Needle vibrating worm wheel (2A)
34	601a	1	1	1	1	1	針振動ギア	Needle vibrating worm wheel (1A, 3A)
35	602	2	2	2	2	2	針振動ギア止ネジ	Screw 11/64"(4.37)×40/6
36	603	1	1	1	1	1	針振受ギア	Needle vibrating worm gear (2A)
37	603a	1	1	1	1	1	針振受ギア	Needle vibrating worm gear (1A, 3A)
38	604	2	2	2	2	2	針振受ギア止ネジ	Screw 15/64"(5.95)×28/4.5
39	605	1	1	1	1	1	針振カム軸	Needle vibrating cam shaft
40	606	1	1	1	1	1	針振カム	Cam (2A)
41	606a	1	1	1	1	1	針振カム	Cam (1A)
42	606b	1	1	1	1	1	針振カム	Cam (3A)
43	607	2	2	2	2	2	針振カム止ネジ	Screw 11/64"(4.37)×40/6
44	608	1	1	1	1	1	針振クランク軸	Zig-zag regulator stud
45	609	1	1	1	1	1	針振クランク軸メタル	Zig-zag regulator stud bushing
46	610	1	1	1	1	1	針振クランク軸メタル止ネジ	Screw 15/64"(5.95)×28/8
47	611	1	1	1	1	1	玉軸土台	Needle vibrating cam roller arm
48	612	1	1	1	1	1	玉軸土台止ネジ	Screw 15/64"(5.95)×28/7
49	613	1	1	1	1	1	玉	Needle vibrating cam roller
50	614	1	1	1	1	1	玉軸	Needle vibrating cam roller stud
51	615	1	1	1	1	1	玉軸ナット	Nut 15/64"(5.95)×28
52	616	1	1	1	1	1	針振調節腕	Needle vibrating bell crank (Rear)
53	617	2	2	2	2	2	針振調節腕止ネジ	Screw 15/64"(5.95)×28/7
54	618	1	1	1	1	1	針振軸カラー	Collar
55	619	1	1	1	1	1	針振軸カラー止ネジ	Screw 1/4"(6.35)×40/4
56	620	1	1	1	1	1	針振調節二又	Forked lever
57	621	2	2	2	2	2	針振調節二又止ネジ	Screw 15/64"(5.95)×28/7
58	622	1	1	1	1	1	針振リンク	Connecting link
59	623	2	2	2	2	2	針振リンク段ネジ	Screw 3/16"(4.76)×32
60	624	1	1	1	1	1	針振調節玉台	Needle bar vibrating bell crank (Front)
61	625	1	1	1	1	1	針振調節玉台コロ	Forked lever driving stud
62	626	1	1	1	1	1	針振調節玉台止ネジ	Screw 15/64"(5.95)×28/7
63	627	1	1	1	1	1	針振ロット	Needle vibrating connection
64	628	1	1	1	1	1	ネジ	Screw 9/64"(3.57)×40/14
65	629	1	1	1	1	1	ナット	Nut

From the library of: Diamond Needle Corp.

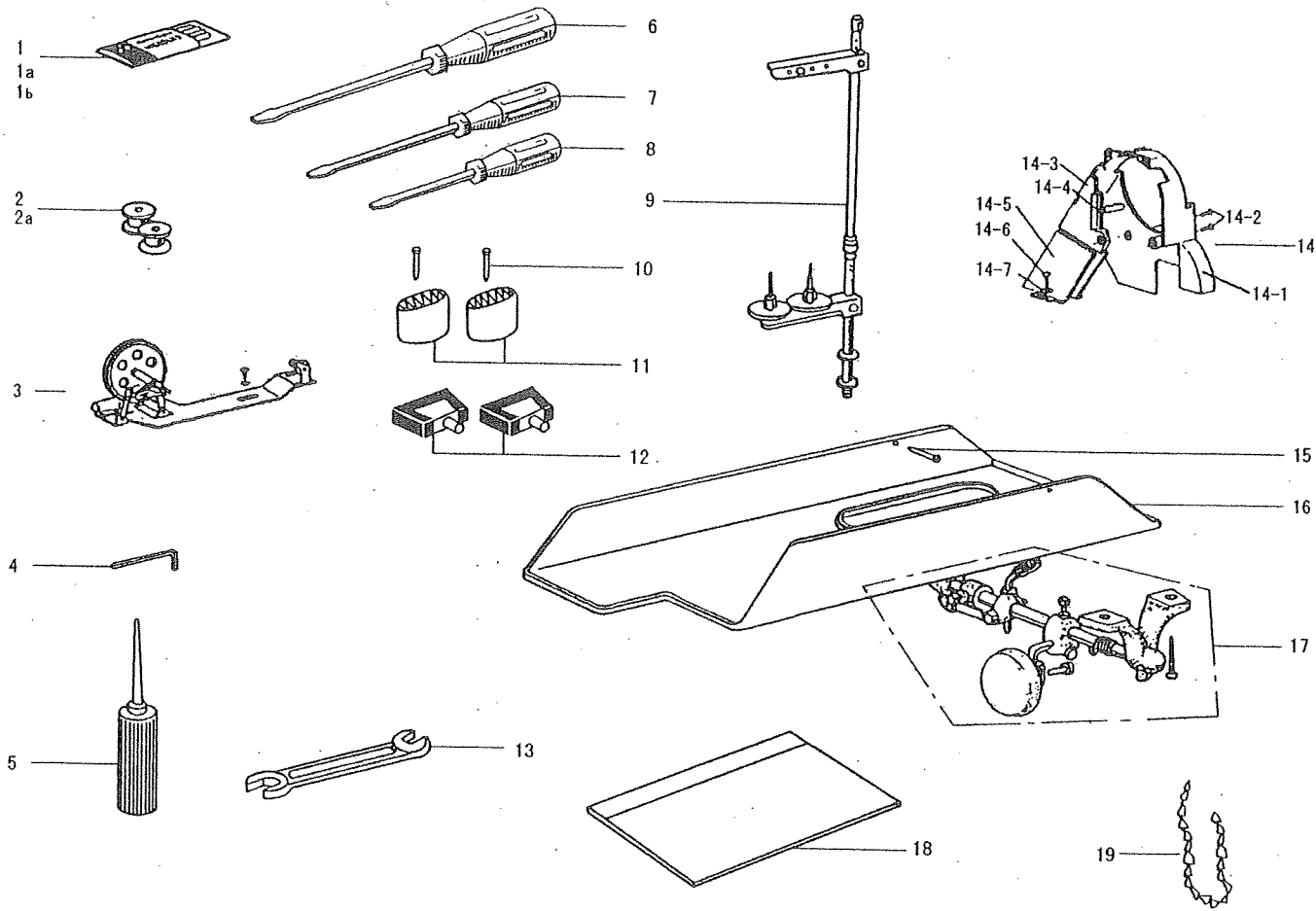

ACCESSORIES

NO	部品番号 PART NO	146RB- *A-1	199RB- *A-1	199R- *A-1	146RBL- *A-1	199RBL- *A-1	品名	PARTS NAME
1	1	4			4		針セット	Needle DP×17 18#
2	1a		4			4	針セット	Needle DP×5 16#
3	1b			4			針セット	Needle DP×5 14#
4	2	2	2		2	2	ボビン	Bobbin (Large)
5	2a			2			ボビン	Bobbin (Small)
6	3	1	1	1	1	1	糸巻キセット	Bobbin winder complete
7	4	1	1	1	1	1	六角レンチ(3ミリ)	Wrench (3mm)
8	5	1	1	1	1	1	油差し	Oiler
9	6	1	1	1	1	1	ドライバー(大)	Screw driver (Large)
10	7	1	1	1	1	1	ドライバー(中)	Screw driver (Middle)
11	8	1	1	1	1	1	ドライバー(小)	Screw driver (Small)
12	9	1	1	1	1	1	糸立台セット	Thread stand assy
13	10	4	4	4	4	4	釘	Nail
14	11	4	4	4	4	4	防振ゴム	Vibration preventing rubber
15	12	2	2	2	3	3	チョウバンセット	Table hinge with rubber cushion
16	13	1	1	1	1	1	スパナ	Spanner
17	14	1	1	1	1	1	ベルトカバー(組)	Belt cover complete
18	14-1	1	1	1	1	1	ベルトカバー1	Belt cover 1
19	14-2	2	2	2	2	2	ネジ	Screw 15/64" (5.95) × 28/8
20	14-3	1	1	1	1	1	ベルトカバー(組)	Belt cover 2 complete
21	14-4	1	1	1	1	1	ネジ	Screw M4×12.5
22	14-5	1	1	1	1	1	ベルトカバー3	Belt cover 3
23	14-6	2	2	2	2	2	丸木ネジ	Screw 4.5×20
24	14-7	2	2	2	2	2	ミガキ座金	Washer
25	15	4	4	4	8	8	釘	Nail
26	16	1	1	1	2	2	油タンク	Oil tank complete
27	17	1	1	1			ヒザ上ゲセット	Knee lifter assy
28	18	1	1	1	1	1	ビニールカバー	Vinyl cover
29	19				1	1	チェーン	Chain